

Part No. 99-0152

HH 50

Riveting head for installing rivet nuts and rivet studs from M3 to M12

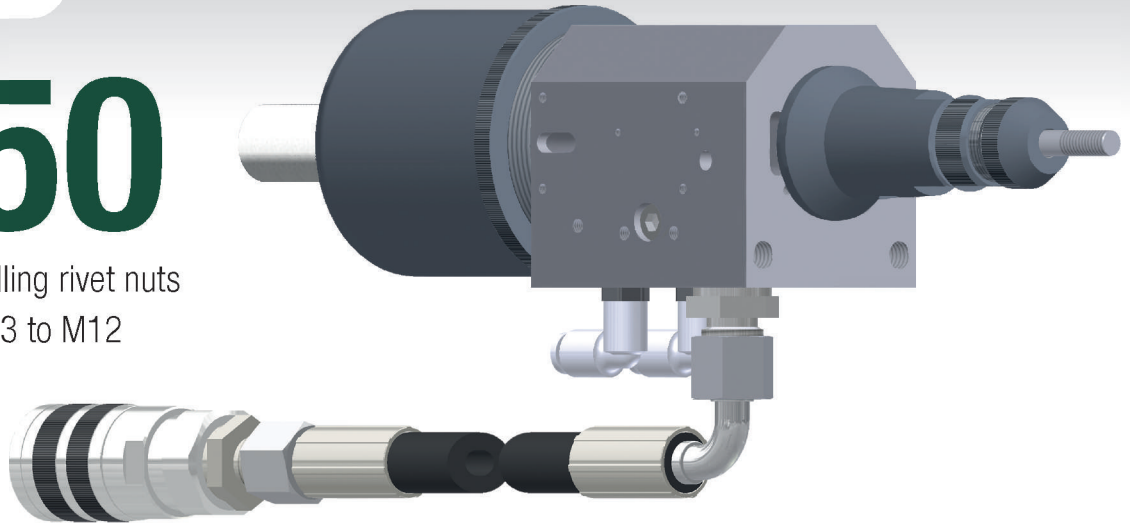

Scope of use:

Rivet nuts	M3	M4	M5	M6	M8	M10	M12
Aluminium, Brass	✓	✓*	✓*	✓*	✓*	✓	✓
Steel	✓	✓*	✓*	✓*	✓*	✓	
Stainless	✓	✓*	✓*	✓*	✓*	✓	

Mandrels & anvils included:

			✓			
--	--	--	---	--	--	--

* including pulling bolts

Description:

- high output at small dimensions
- exact smooth stroke adjustment
- simple operation, reliability
- low noise
- low transferred vibrations

Technical parameters:

Model	HH 50
Pulling Force up to	18.2 kN / 35 MPa*
Working Stroke	1.5–8.0 mm
Weight	2.8 kg*
Work Cycle up to	15 cycles / min*
Dimensions (l×w×h)	280 × 70 × 78 mm
Max Oil Pressure	35 MPa
Volume of Head	0.005 l
Air Consumption for Exhaust Process	20 l / rivet
Working Air Pressure for Engine	5–7 bar

* depends on power unit, size and type of rivet



RHP P2



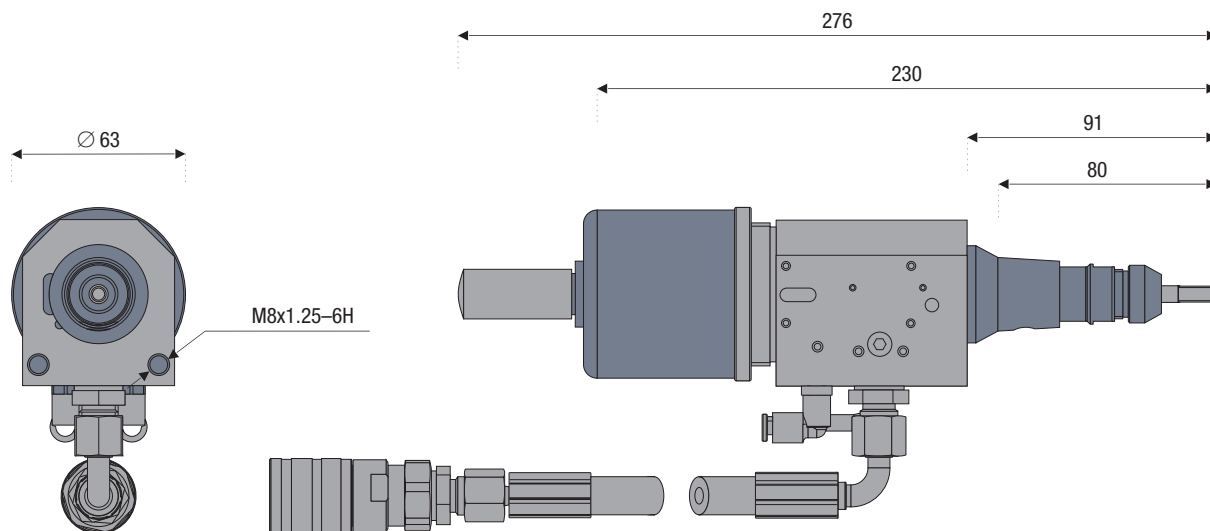

Dimensions of tool:

HH 50



Anvils, mandrels and pulling bolts:

TC 50			
M3	87-0026	87-0039	
M4	87-0027	87-0040	87-0046
M5	87-0028	87-0041	87-0047
M6	87-0029	87-0042	87-0048
M8	87-0030	87-0043	87-0049
M10	87-0031	87-0044	
M12	87-0032	87-0045	

Optional accessories:

Description	Part No.
RHP P2	99-0100
Hydraulic Oil - 1 Litre	87-0188
Oil for Pneumatic Engine	87-0427